

CONCESSIONS

ROLLING COUNTER SHUTTERS

500



WAYNE DALTON COMMERCIAL DOOR SYSTEMS

500 SERIES

ROLLING COUNTER SHUTTERS

EXCEPTIONAL SECURITY AND AESTHETICS

The Wayne Dalton Rolling Counter Shutter system provides the perfect solution for smaller openings that require visually appealing access control. Our 500 Series Shutters are designed to be utilized in those applications that incorporate counter tops or openings that require the shutter to rest on a sill. With several different modes of operation including lift-up, awning crank and motor, the Wayne Dalton Rolling Counter Shutter is the preferred solution for your application. Whether it's a concession stand, accounts payable window, sports arena or school food service, the 500 Series is the counter shutter of choice.



- 2" FLAT SLATS
- SIZES UP TO 20' WIDE AND 8' HIGH
- AVAILABLE IN STEEL, STAINLESS STEEL AND ALUMINUM
- POWDER COAT FINISH AVAILABLE

ROLLING COUNTER SHUTTERS

500 SERIES

The Wayne-Dalton 500 Series Rolling Counter Shutters combine aesthetics and security in a compact unit ideal for smaller openings or restricted space applications. Designed to fit openings up to 20' wide and 8' high, these reliable doors are an ideal choice for commercial, retail, corporate and professional applications.

Durable Materials with Stylish Features

The high quality, interlocking slats on the rolling counter shutter are available in galvanized steel, stainless steel or aluminum for long-lasting durability. The "box" type guides are designed to reduce operational noise as well as to conceal the fasteners used to attach the shutter to the jamb resulting in quieter operation and greater visual appeal. A square hood cover encloses the curtain coil and counterbalance mechanism giving a clean, professional appearance.

Performance

The counterbalance assembly utilizes a spring barrel design which encases the mechanism while providing an axis around which the curtain coils. Oil-tempered, torsion-type counterbalance springs are wound from steel, providing accuracy in balancing the door.

A spring tension adjusting wheel is normally mounted outside the bracket on the end of the tension rod. An inside adjusting wheel for tight side-room applications is available in limited sizes.

Based on the needs of the application, there are a variety of operational choices. Counter shutter operation can be manual push-up, chain, crank, or motor-operated. Door mounting can be self-supporting (using structural tubes) or directly on to the building structure.

Attractive Options

For the ultimate in custom appearance, powder coating is available in 180 colors. The flexibility in color choice results in a finish that radiates beauty and smoothness to produce an aesthetically pleasing curtain to suit any decor.

An optional concealed bottom bar cylinder lock activates steel tamper proof lock rods. The lock uses a standard mortise cylinder and is available with an optional removable core.

Optional

- Powder Coat Finish
- Slide Locks
- Cylinder Locks
- Center Locking
- Counter Cutouts
- Mullion Systems
- Sensing Edges
- Secur-Vent®
- Fascias
- Integral Frame Units

Operation

- Lift-Up
- Awning Crank
- Motor (Including Tube Motor)



Steel Rolling Shutter



Aluminum Rolling Shutter



Stainless Steel Integral Frame Unit

Slat Profiles



No. 17 – 2" Flat-faced slat up to 20-gauge steel, 20-gauge stainless steel, or 16 B&S gauge aluminum (mill, clear, or bronze anodized).
Depth: 1/2", 1-7/8" on centers.



Secur-Vent® – Perforated slat provides optimal security and ventilation. Slat consists of 1/16" diameter hole offering 41% open area over length of each slat. Available in galvanized steel, stainless steel and aluminum.

ROLLING COUNTER SHUTTERS

500 SERIES

MANUAL OPERATION

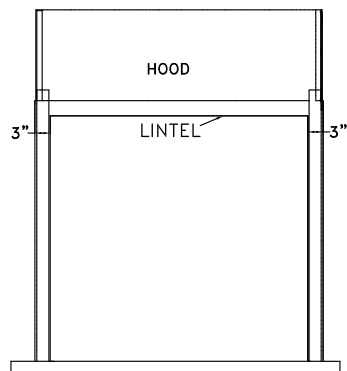

ELEVATION

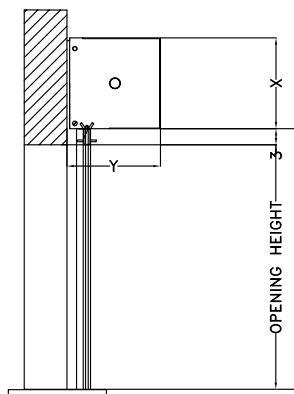

SECTION (FACE MOUNTED)

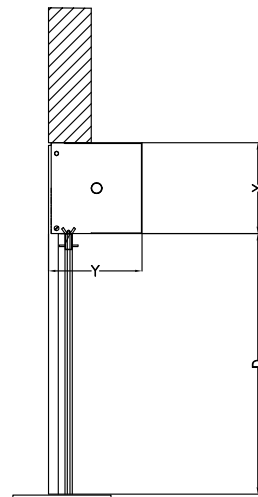

SECTION (UNDER LINTEL)

TUBE MOTOR OPERATION

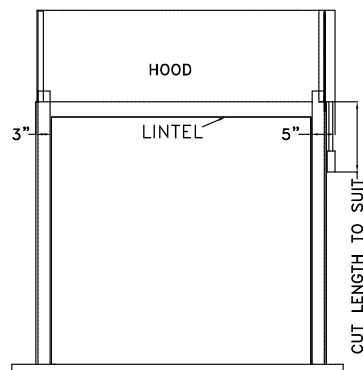

ELEVATION

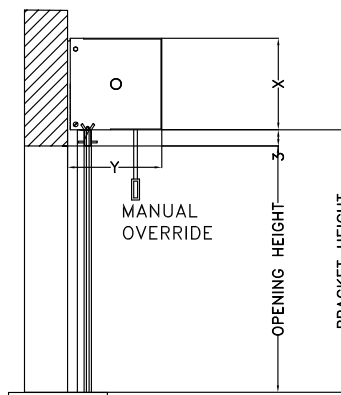

SECTION (FACE MOUNTED)

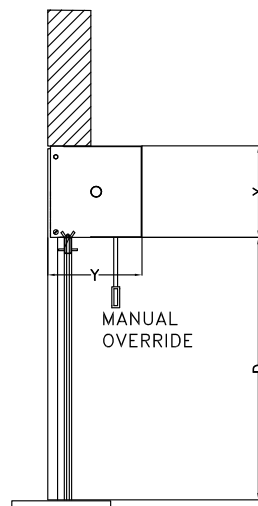

SECTION (UNDER LINTEL)

COMMON GUIDE MOUNTING OPTIONS

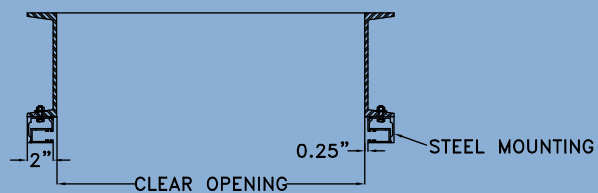

FACE MOUNTED TO STEEL

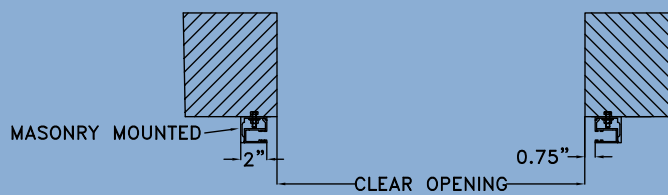

FACE MOUNTED TO MASONRY

ROLLING COUNTER SHUTTERS

500 SERIES

CRANK OPERATION

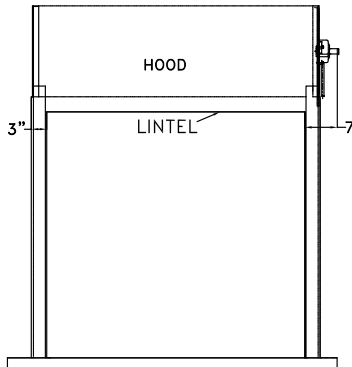

ELEVATION

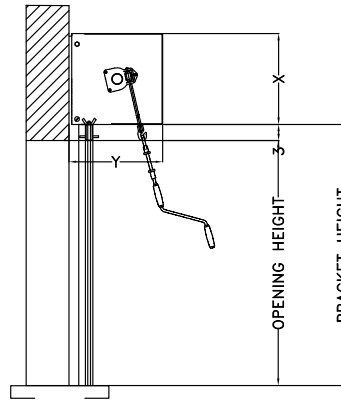

SECTION (FACE MOUNTED)

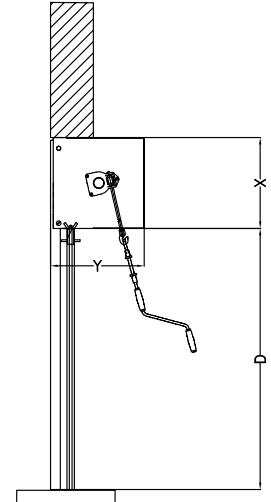

SECTION (UNDER LINTEL)

MOTOR OPERATION

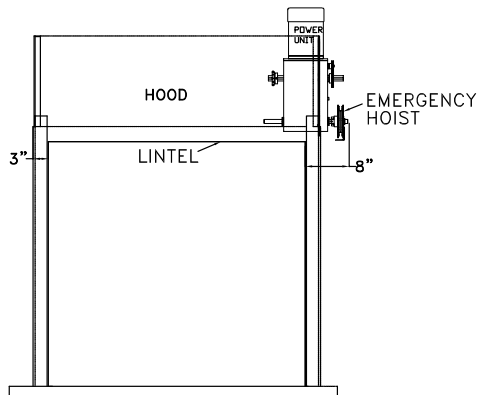

ELEVATION

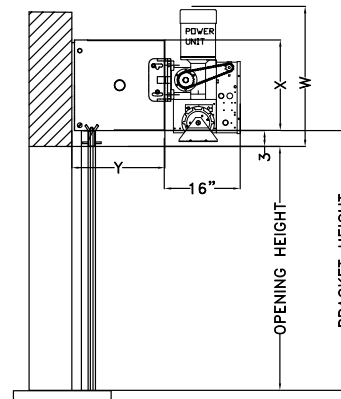

SECTION (FACE MOUNTED)

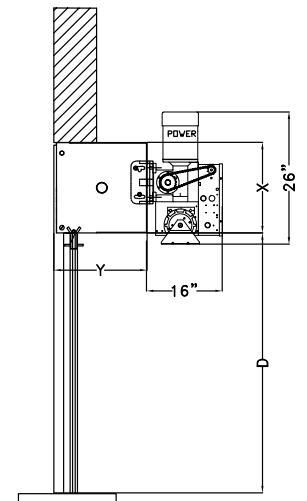

SECTION (UNDER LINTEL)



ROLLING COUNTER SHUTTERS

500 SERIES

ALUMINUM SHUTTER

WIDTH	HEIGHT	BRACKET SIZE	X	Y	W	R	L
10'	6'6"	9'	9-1/2"	9-1/8"	13"	See sketch	See sketch
12'	8'	11'	11-1/2"	11-1/8"	15"	See sketch	See sketch
16'	6'	11'	11-1/2"	11-1/8"	15"	See sketch	See sketch
20'	6'	11'	11-1/2"	11-1/8"	15"	See sketch	See sketch

STEEL / STAINLESS STEEL SHUTTER

WIDTH	HEIGHT	BRACKET SIZE	X	Y	W	R	L
9'	7'	9'	9-1/2"	9-1/8"	13"	See sketch	See sketch
11'	7'	11'	11-1/2"	11-1/8"	15"	See sketch	See sketch
15'	6'	11'	11-1/2"	11-1/8"	15"	See sketch	See sketch
20'	6'	11'	11-1/2"	11-1/8"	15"	See sketch	See sketch



ROLLING COUNTER SHUTTERS

Note to specifiers: Words in parentheses indicate frequently specified and highly recommended options.

PART I – GENERAL

1.01 Work Included

- A. The opening will be equipped with Wayne-Dalton Rolling Counter Shutter Series (500) (510) (520).

1.02 Related Work

- A. Opening preparation, miscellaneous or structural metal work, access panels, finish or field painting, field electrical wiring, wire, conduit, fuses, and disconnect switches are in the Scope of Work of other divisions or trades.

1.03 Reference Standards

- A. **ANSI/DASMA203** –American National Standards. Institute Specifications for non-rated fire rolling doors published by Door & Access Systems Manufacturers Association International.
- B. **ASTM A123** – Zinc (hot-dipped galvanized) coating on iron and steel products.
- C. **ASTM A229** – Steel wire, oil-tempered for mechanical springs.
- D. **ASTM A-653-94** – Steel sheet, zinc-coated (galvanized) by the hot-dipped process, commercial quality.

1.04 Quality Assurance

- A. Rolling doors and all accessories and components required for complete and secure installations shall be manufactured as a system from one manufacturer.

1.05 Systems Description

- A. Rolling Door: Type:
500 Series Rolling Counter Shutters
- B. Mounting: (steel) (wood) (masonry) (drywall over 16 gauge minimum steel studs or wood studs) jambs
- C. Operation: (manual push-up) (crank) (tube motor)
- D. Material: Galvanized steel with polyester finish paint

1.06 Submittals

- A. Shop Drawings: Clearly indicate the following:
 - 1. All details required for complete operation and installation.
 - 2. Hardware locations.
 - 3. Type of metal and finish for door sections.
 - 4. Finish for miscellaneous components and accessories.
- B. Product Data: Indicating manufacturer's product data and installation instructions.

1.07 Delivery, Handling, Storage

- A. Deliver products in manufacturer's original containers, dry, undamaged, seals and label intact.
- B. Store and protect products in accordance with manufacturer's recommendations.

1.08 Warranty

- A. Standard manufacturer's ONE YEAR warranty against defects in material and workmanship.

PART II – PRODUCTS

2.01 Curtains

- A. Curtains will be comprised of (extruded aluminum interlocking 1 1/2" flat slats, .050" thick – 16 B&S gauge) (flat faced, two inch, No. 17 slats, galvanized, bonderized, 20 gauge steel) (flat faced No. 17 slats of 20 gauge stainless steel). Alternate slats will be fitted with end locks to hold curtain in alignment.
- B. Bottom of curtain will be finished with an extruded, tubular, or single angle bottom bar fitted with a continuous vinyl bumper to protect counter top.

2.02 Frames

- A. Pre-assembled Integral frame units are available in stainless steel to suit wall thickness, consisting of 16 gauge jambs and head, hood and fascia, and 14 gauge sill. Grooves are formed into sides of frame for retaining curtain. Maximum clear opening is 12' wide and 5' high. Wall thickness limitations 3-5/8" (minimum) and 21" (maximum). Sill may be omitted when so specified.

2.03 Guides

- A. Guides will be formed from extruded aluminum shapes of 6063 alloy (clear anodized) and will extend above lintel so as to furnish support for brackets. Continuous strips of wool pile will be inserted into guides to eliminate metal-to-metal contact and to provide dust-seal around curtain.

2.04 Brackets

- A. Brackets will be of (1/8" minimum thick aluminum) (3/16" minimum steel) (3/16" minimum stainless steel) plates with permanently sealed ball bearings. Designed to enclose ends of coil and provide support for counterbalance pipe at each end.

2.05 Counterbalance

- A. Curtain to be coiled on a pipe of sufficient size to carry door load with deflection not to exceed .033" per foot of door span and to be correctly balanced by helical springs, oil tempered torsion type. Cast iron barrel plugs will be used to anchor springs to tension shaft and pipe.

2.06 Hood

- A. Hoods will be minimum 24-gauge (aluminum, 22 gauge B&S) (galvanized) (stainless steel) sheet metal, flanged at top for attachment to header and flanged at bottom to provided longitudinal stiffness. Hood will enclose curtain coil and counterbalance mechanism.

2.07 Finish

- A. Curtain, bottom bar, and hood will be (aluminum, clear or bronze anodized) (steel, gray baked-on prime) (stainless steel #4). Powder coating available in 180 colors.

2.08 Operation

- A. Manual shutters, standard to 10'0" wide, will be operated by means of lift handles on bottom bar. Shutters over 10'0" wide will be operated by removable awning crank with crank box mounted on end of spring barrel. Tube motor operation available.

2.09 Locking

- A. Curtain will be locked at each end of bottom bar by concealed slide bolts which will engage in a developed slot in each guide. Cylinder lock can be provided at jambs or in center of bottom bar at an extra cost.

PART III – EXECUTION

3.01 Installation

- A. General:
 - 1. Install rolling shutters in accordance with Wayne-Dalton's instructions and standards. Installation shall be by a trained door systems technician.
 - 2. Verify that existing conditions are ready to receive rolling shutter.
 - 3. Beginning of rolling shutter work means acceptance of existing conditions.
- B. Install shutter complete with necessary hardware, jamb and head mold strips, anchors, inserts, hangers, and equipment supports in accordance with final shop drawings, manufacturer's instructions, and as specified herein.
- C. Fit, align and adjust rolling shutter assemblies level and plumb for smooth operation.
- D. Upon completion of final installation, lubricate, test and adjust shutter to operate easily, free from warp, twist or distortion and fitting for entire perimeter.

Note: Architect may consider providing a schedule when more than one rolling door or opening type is required.

Because of continuing product improvements, we reserve the right to change the product specifications and design without prior notice.

Distributed By:



Authority Dock & Door

877-247-2935

www.authoritydockanddoor.com

For technical information, visit:

www.Wayne-Dalton.com/commercial

©2013 Wayne-Dalton, a division of Overhead Door Corporation. Consistent with our policy of continuing product improvement, we reserve the right to change product specifications without notice or obligation. **Item 348442**



Printed in U.S.A.